

ISO 9001
BUREAU VERITAS
Certification



UKAS
Quality Management
003

We recommend Renault Trucks Oils

99, Route de Lyon - 69806 Saint-Priest Cedex - France
Tel. +33 (0) 4 69 09 60 00

RENAULT TRUCKS DELIVER

PRODUCT

TECHNICAL AND COMMERCIAL KNOWLEDGE

ALL ABOUT FUEL-FILLING ANTI-THEFT AND ANTI-SPILLAGE DEVICES



RENAULT TRUCKS DELIVER

PRODUCT

TECHNICAL AND COMMERCIAL KNOWLEDGE



renault-trucks.com

Renault Trucks SAS with a capital of 50 000 000 € - 954 506 077 RCS Lyon - Crédit photos : © Renault Trucks - 04/2017 - C&Bproject



renault-trucks.com



FACT

Fuel theft is a common problem that causes standstill and can lead to damage to the truck, with potential economic consequences. Fuel spillage can lead to accidents.

Renault Trucks offers a device consisting of a perforated basket that inhibits fuel siphoning, combined with a spring-mounted, self-closing lid to prevent fuel spills. By equipping the truck with both of these devices one can avoid potentially costly problems that could lead to downtime.

The anti-spillage lid is standard on trucks built after June 2012. The anti-theft device can be installed on our new trucks or retro-fitted as accessory.

| FEATURES | BENEFITS |
|---|---|
| Anti-theft device. | <ul style="list-style-type: none">Reduces the risk of fuel theft.Prevents siphoning and skimming. |
| Anti-spillage device, self-closing lid. | <ul style="list-style-type: none">Prevents excessive evaporative emissions and spillage.Prevents risk of fire/minimizes risk of accidents.Positive effect on the environment. |
| Perfect geometry of design. | <ul style="list-style-type: none">Excellent functionality when filling up with fuel. |
| Made of high quality steel. | <ul style="list-style-type: none">Durable, corrosion resistant, economical. |



REDUCE
RISK OF FUEL
THEFT
AND SPILLAGE



THE PROMISE OF A GENUINE RENAULT TRUCKS PART

A test was performed on a competitor's product, which was similarly designed. The test showed that the anti-siphoning device caused problems with refueling. It took very long time to fill the tank with this device fitted, since the nozzle constantly shut off the fuel. It was observed that this is because the geometric properties of the basket are not perfectly designed, so, they automatically cause the filler nozzle to stop. Renault Trucks' anti-theft device is designed with perfect geometric properties for unproblematic refueling.

1 | DURABILITY

The devices are manufactured from high quality steel, with the correct properties. They're designed and engineered expertly, for a long product lifetime.

2 | RELIABILITY, MAINTAINABILITY AND ECONOMY

When using Renault Trucks' anti-theft and anti-spillage devices on your truck the risk of downtime and costly repairs is decreased. Owing to the high-quality steel it's made from, this durable and corrosion-resistant product will last longer and provide good value for money.

3 | ENVIRONMENT AND SAFETY

With the anti-spillage device you minimize the leakage of diesel, thus contributing to environmental protection, and also fewer accidents.

Fuel spillage on road can cause slippery conditions, and fuel spillage outside the tank can cause fire. The products are designed to prevent fire risk, therefore meeting EU regulation ECE-R34.

FUEL-FILLING ANTI-THEFT AND ANTI-SPILLAGE DEVICES - HOW IT WORKS

The devices are made from a corrosion-resistant, ductile and weldable type of stainless steel. The anti-theft device consists of a cylindrical perforated basket with an anti-siphoning function. On its top, it incorporates an anti-spillage device equipped with a spring lid. This lid is designed to close tightly and minimize fuel leakage, even when the fuel cap is missing.

These devices prevent the theft of diesel and ensure that no fuel is spilled either while filling the tank or driving, if the tank cap is missing for any reason.

The anti-theft device cannot be removed without seriously damaging the tank. It can be used on all D-shaped metal fuel tanks. The anti-theft device can be installed very quickly: no tools are needed. The wings on the sides prevent removal of the device once it's been fitted.

The anti-spillage lid fits filling necks that are equipped with the anti-theft device as well as those without it. When the customer wants to add an anti-theft device to their truck, the anti-spillage lid can be moved over: there's no need to purchase a new lid.

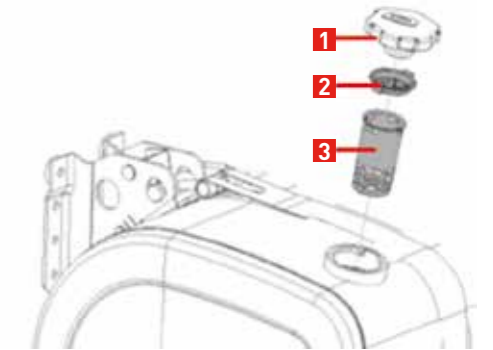

- 1 Anti-theft protection basket
- 2 Anti-spillage device
- 3 Fuel cap

EXTENSIVE TESTING

The following tests have been successfully performed.

- **On-truck tests:**
 - Field tests on customer-owned trucks.
 - A summer test, carried out in Spain over an eight-week period: mostly on ordinary roads, but also on test tracks.
 - A winter test, carried out in northern Sweden during rough conditions with snow, ice and freezing rain.
 - An AET (Accelerated Endurance Test), performed on a test track over a six-month period to simulate a vibration environment equivalent to a truck's whole life cycle.
- **Removal tests of anti-theft baskets.**
- **Skilled mechanics were given the task of removing an anti-theft device installed on the tank, using different tools of their choice and without any time constraints: they were unable to do so.**

SERVICE

Only by having Genuine Renault Trucks Parts fitted in an authorized Renault Trucks workshop by a certified and fully trained technician can the best possible levels of service, uptime and efficiency be ensured.

PRACTICAL ADVICE

For more information, have a look on our accessories e-catalogue available on our Renault Trucks website : <http://www.renault-trucks.co.uk/accessories/>

RENAULT FITTED-PART

- One year warranty.
- Fitted by Renault Trucks trained technicians.

RENAULT TRUCKS 24/7

- Professional roadside assistance 24 hrs a day, 7 days a week, 365 days a year.
- Dedicated to getting customers' trucks back on the road with minimum delay.